

net.power

Valve regulated lead-acid batteries



Motive Power Systems

Reserve Power Systems

Special Power Systems

Service

Your benefits with HOPPECKE net.power

- **Maintenance-free regarding water refilling** - due to Absorbent Glass Mat-technology
- **Maximum compatibility** - dimensions analogues to 19" and 23" standards
- **Good high-current capability** - low investment costs due to innovative electrode structure
- **Optimum operational safety** - integrated backfire protection and central degassing system
- **Higher short-circuit safety even during the installation** - based on HOPPECKE system connectors
- **Easy assembly and installation** - battery lid with integral handle

Typical applications of HOPPECKE net.power

- **Telecommunications**
Mobile phone stations
BTS-stations
Off-grid/on-grid solutions
- **Emergency power supply and security lighting**
- **Uninterruptible power supply**



Similar to the illustration

**Longer life based on new
ESS Technology**



HOPPECKE

POWER FROM INNOVATION

Type overview

Capacities, dimensions and weights

Type	C ₁₀ /1.80 V Ah	C ₅ /1.75 V Ah	C ₃ /1.70 V Ah	C ₁ /1.70 V Ah	C _{1/2} /1.65 V Ah	C _{1/6} /1.60 V Ah	Max. Weight kg	Length L mm	Width W mm	Height H mm	Fig.
net.power 12 V 92	85.0	75.0	69.0	54.0	44.1	34.5	30.0	396	105	273	A
net.power 12 V 100	100.0	96.5	89.7	73.9	64.5	45.7	42.8	541	125	217	B
net.power 12 V 150	155.0	143.0	133.8	111.0	95.5	67.5	61.9	541	125	302	C
net.power 12 V 170	166.0	156.0	146.7	121.0	101.4	71.1	64.5	541	125	302	C

C₁₀, C₅, C₃, C₁, C_{1/2} and C_{1/6} = Capacity at 10 h, 5 h, 3 h, 1 h, 1/2 h and 1/6 h discharge

Fig. A

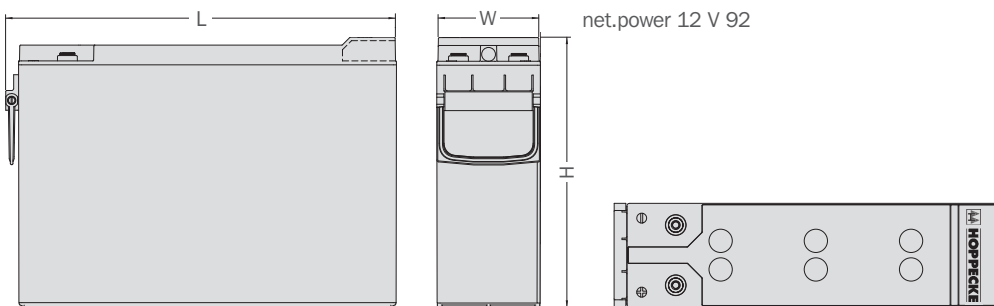

Fig. B

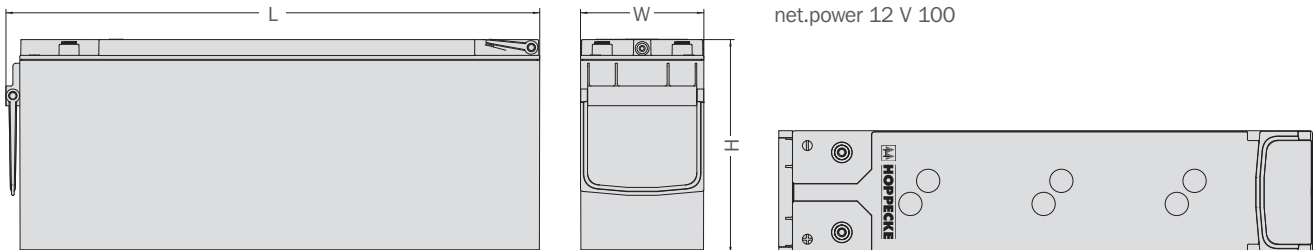
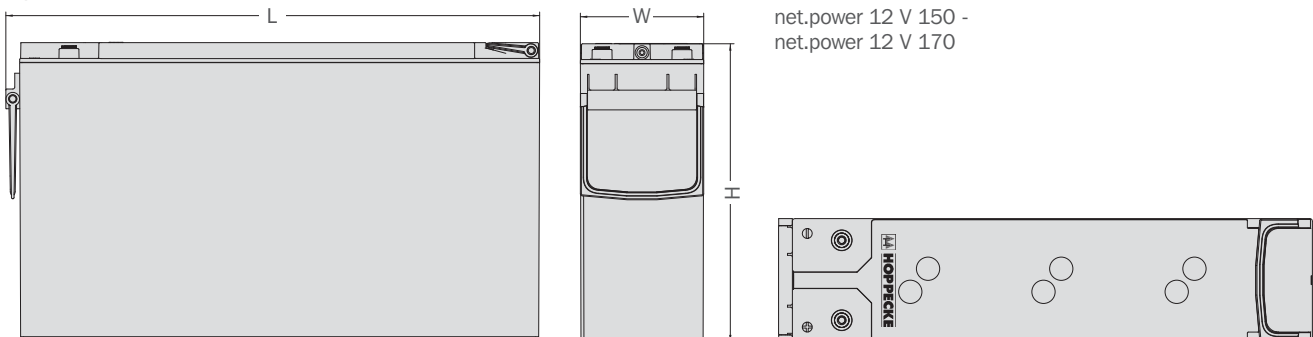

Fig. C



Design life: ≥ 12 years (according to EUROBAT)

Optimal environmental compatibility - closed loop for recovery of materials in an accredited recycling system.