

OPzS bloc solar.power

Vented lead-acid battery for cyclic applications



Motive Power Systems

Reserve Power Systems

Special Power Systems

Service

Your benefits with HOPPECKE OPzS bloc solar.power

- **Very high cycle stability during PSoC¹ operation** - due to tubular plate design with efficient charge current acceptance
- **Maximum compatibility** - dimensions according to DIN 40737-3
- **Easy assembly and installation** - battery lid with integral handle
- **Higher short-circuit safety even during the installation** - based on HOPPECKE system connectors
- **Extremely extended water refill intervals up to maintenance-free** - optional use of AquaGen[®] recombination system minimizes emission of gas and aerosols²



Similar to the illustration, AquaGen[®] optional

Typical applications of HOPPECKE OPzS bloc solar.power

- **Solar-/Off-grid applications**
Power supply for remote off-grid applications and isolated power networks, drinking water supply systems, healthcare facilities
- **Traffic systems**
Signalling systems, lighting
- **Telecommunications**
Mobile phone stations, BTS-stations, off-grid/on-grid solutions

Type overview

Capacities, dimensions and weights

Type	C ₁₀₀ /1.85 V Ah	C ₅₀ /1.85 V Ah	C ₂₄ /1.83 V Ah	C ₁₀ /1.80 V Ah	C ₅ /1.77 V Ah	max. Weight kg	Weight electrolyte kg (1,24 kg/l)	max.* Length L mm	max.* Width W mm	max.* Height H mm	Fig.
12V 1 OPzS bloc solar.power 70	70.0	65.0	60.0	50.0	44.0	37.0	15.0	272	205	383	A
12V 2 OPzS bloc solar.power 130	130.0	130.0	120.0	101.0	88.0	48.0	13.0	272	205	383	A
12V 3 OPzS bloc solar.power 200	200.0	190.0	180.0	151.0	132.0	67.0	18.0	380	205	383	A
6V 4 OPzS bloc solar.power 270	270.0	255.0	240.0	202.0	176.0	47.0	13.0	272	205	383	B
6V 5 OPzS bloc solar.power 330	330.0	320.0	297.6	252.0	220.0	60.0	20.0	380	205	383	B
6V 6 OPzS bloc solar.power 400	400.0	380.0	357.6	302.0	263.5	67.0	18.0	380	205	383	B

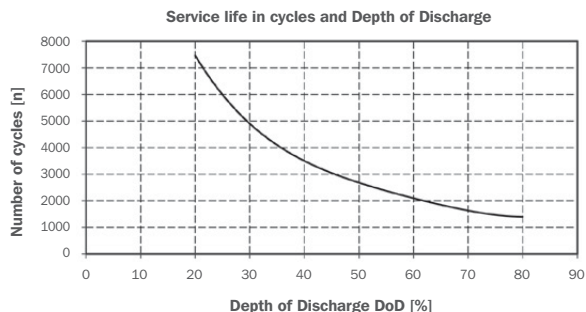

C₁₀₀, C₅₀, C₂₄, C₁₀ and C₅ = Capacity at 100 h, 50 h, 24 h, 10 h and 5 h discharge

* According to DIN 40737-3 data to be understood as maximum values.

Fig. A

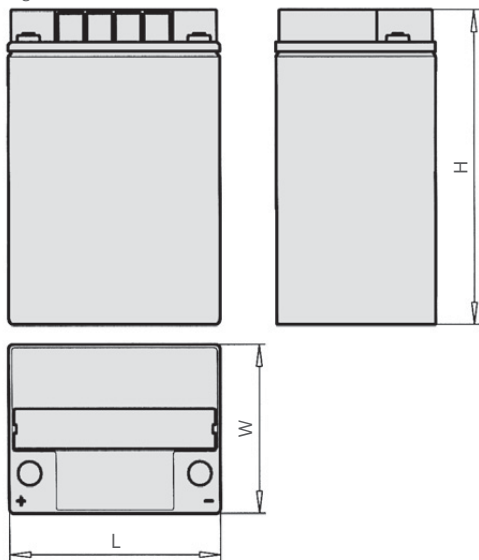

12 V 1 OPzS bloc solar.power 70 - 12 V 3 OPzS bloc solar.power 200

Fig. B

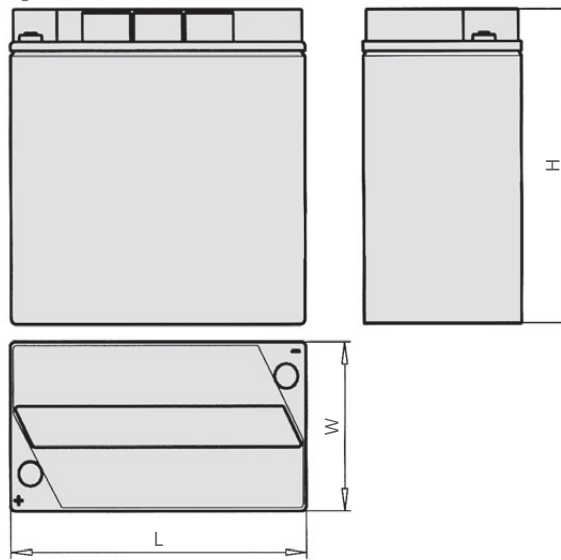

6 V 4 OPzS bloc solar.power 270 - 6 V 6 OPzS bloc solar.power 400

Optimal environmental compatibility - closed loop for recovery of materials in an accredited recycling system.

IEC 60896-11
IEC 61427

¹ Partial State of Charge

² Similar to sealed lead-acid batteries